

# FOOD SLICERS

## Automatic slicer - model A812

Automatic food slicer A812 (A812T with teflon-coated knife for slicing cheese) with constant of cutting upcast and counter of cutting combs is a precise machine which allows the cutting of food into slices of different thickness. Equipped with an electronic counter of cut combs has features:

- ⊙ counting the slices in automatic mode
- ⊙ the machine off when it detects the absence of material to cut
- ⊙ the maximum number of slices inflicted: 999
- ⊙ After executing the given number of slices the slicer is off automatically.

Slicer meets the CE standards for safety and hygiene.



## DESCRIPTION

### Model Range

812

## SPECIFICATIONS

### Finish

Elements of the cutter in contact with food made from stainless steel

### Knife Material

Stainless chromium steel

### Diameter of Knife

300 mm

### Knife sharpener

Professional, integral with the machine

### Slice Thickness

0 - 25 mm

### Product sliced

Cold cuts, cheese, meat, bread

### Product Limitations

The products should not be sliced:

- ⊙ frozen goods
- ⊙ products with bones
- ⊙ non food products

### Product Capacity

42 slices per minute

### Recommendation

It is recommended to cut the cheese into slices cooled to the temperature 7 - 10 °C. The machine elements in contact with food should be washed every day, dry after washing. It is forbidden to wash all machine with water stream. Every day lubricate with machine oil (do not use cooking oil). In order to avoid premature rub the sharpener, only the clean knife should be sharpen (without the remnants of cut product).

### Approvals

Machine corresponds to the requirements of the following reference documents:

- ▶ Machinery Directive 2006/42/WE and norms harmonized:
  - ⊙ EN 60204-1:2006+A1:2009 (Electric safety)
  - ⊙ EN 953:1997+A1:2009 (Covers of moving parts)
  - ⊙ EN 1974:1998+A1:2009 (Slicers - health and safety requirements)

**DIMENSION CHART**

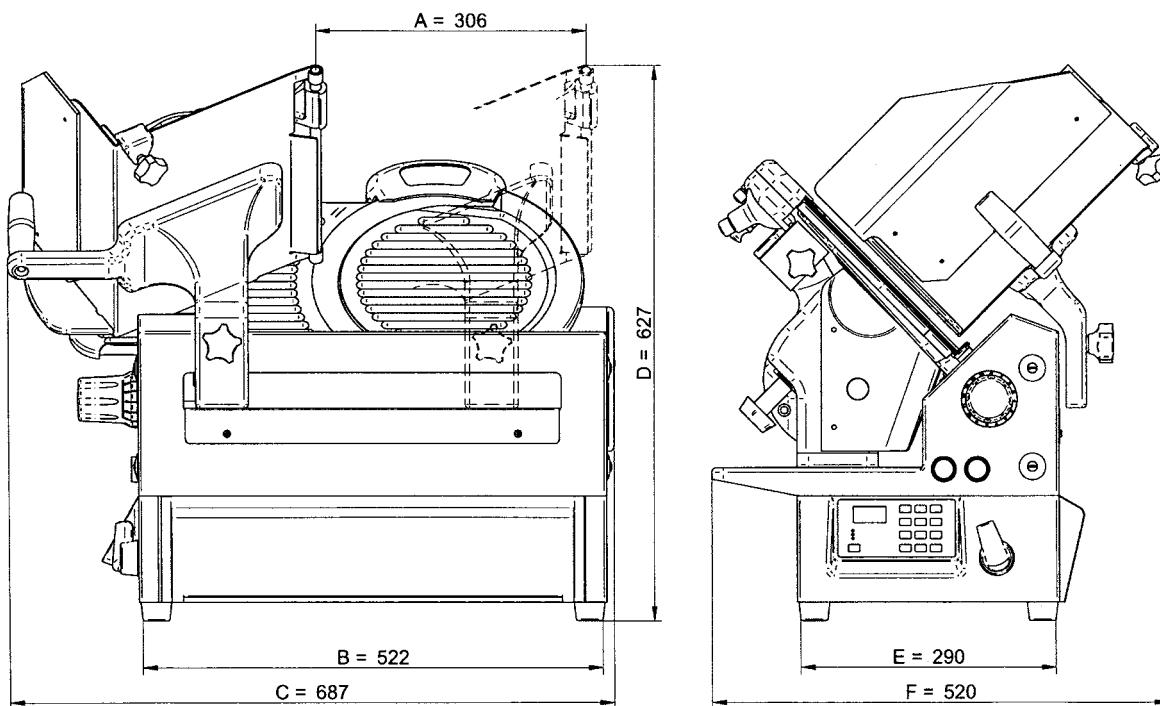

**DIMENSIONS**

Slicers: A812, A812T					
<b>A</b>	306 mm	<b>C</b>	687 mm	<b>E</b>	290 mm
<b>B</b>	522 mm	<b>D</b>	627 mm	<b>F</b>	520 mm

**TECHNICAL DATA (specification)**

Slicers: A812, A812T	
<b>Overall dimensions</b>	635 x 500 x 540(H) mm
<b>Foot print</b>	495 x 255 mm
<b>Slice thickness</b>	0 - 25 mm (liquid regulation)
<b>Max. cutting size</b>	230 mm (length), height depends on length, max. 190 mm
<b>Diameter of knife</b>	300 mm
<b>Sound level</b>	≤ 70 dB
<b>Electrical</b>	230V 50Hz 1 phase
<b>Power</b>	250W (knife drive), 180W (driver table).
<b>weight (net)</b>	50 kG
Options	
Electrical 115V 60Hz 1 phase	
Comments	
A812T slicer is intended primarily for slicing cheese, different from the A812 slicer the fact that the knife, knife cover, resistance plate are teflon coated and there was reinforced the drive with powerful engine.	

**SHIPPING SPECIFICATIONS**

Chest Dimmensions				
Slicers	Lenght	Width	Height	Gross Weight
A812	650mm	550mm	760mm	75kG
A812T	650mm	550mm	760mm	75kG